

HEXATECH	<b>Electrical Method Statement for Conduit, Trunking, Tray, Ladder and Cabling Installation</b>	Issue No.: 1	Document Effective Date: 01 Mar 2017	Page 1 of 14
		Rev. No.: 0		Document Ref: MS-E008

## 1.0 OBEJECTIVE

This procedure provides details for Conduit, Trunking, Tray, Ladder and Cabling installation with Quality Control and Safety Plan pertaining to this project.

## 2.0 SCOPE OF WORKS

Method of installation is in accordance to the latest IEC, IEE, MS and local authority standards.

## 3.0 REFERENCES

- a) IEC 62305 Part 1 to 3
- b) BS 7430:1991

## 4.0 HANDLING AND STORAGE

Only approved site lay down areas, will be used for storage and minor modification works. All cable supports will be stored elevated from the ground and covered with canvas to prevent contamination through water and dust.

## 5.0 WORK METHOD STATEMENT

### 5.1 Introduction

The intention of this document is to give an overall idea about the method of installation applied throughout the project. Method of installation is in accordance to the latest IEC, IEE, MS and local authority standards. Certain specified equipment installation methods are in accordance to the manufacturer/supplier recommendation for optimum performance. Whereby required, customization or specific detail shop drawing and erection method can be provided along the project.

### 5.2 Installation of Cable Support Systems

#### 5.2.1 Cable Support System Installation- Ladder, Cable Tray and Trunking

- The raceway routes shall be chosen so as not to interfere with access to equipment and at least above 2.3m above walking surface for operation and maintenance. The detailed routing and location shall be determined in the field to suit the location of equipment and to conform to structural features and avoid interference with other systems and equipment.
- All cable raceway shall be neatly aligned, levelled and adequately supported at regular interval no more than 1.2m apart from the unistrut. The mounting of cable trunking to the slab 'soffit' with the trunking cover facing down shall not be allowed unless approved by client. Earth continuity shall be ensured by means of external copper bonding links at all joints.
- Cut ends of the tray, trunking or ladder shall be grinded to remove sharp edges. All side cuttings shall be protected with paint against corrosion.
- Supports fastened to the structural, column, beam or concrete must be capable of supporting the ultimate trays, trunking or ladder loading capacity and the support strut channel to be selected according to span of two threaded hanger rod. The span between two threaded hanger rod less than 1meter to refer Diagram A and more than 1 meter in span to refer Diagram B. All field welding shall be cleaned and protection paint shall apply.

HEXATECH	<b>Electrical Method Statement for Conduit, Trunking, Tray, Ladder and Cabling Installation</b>	Issue No.: 1	Document Effective Date: 01 Mar 2017	Page 2 of 14
		Rev. No.: 0		Document Ref: MS-E008

- The duty of the ladder shall be selected in relation to the load and length of span in order the deflection of the ladder at mid-point of a span is not greater than span/180.
- Next page shows the steps of assembling the supports (unistrut) using spring nut, bolt, and angle fitting.

Trunking Filling (Filled to max. 60%)

Trunking Size	Space Filled (mm)	Space Avail.(mm)
50 x 50	30 x 50	20 x 50
50 x 75	30 x 75	20 x 75
50 x 100	30 x 100	20 x 100
75 x 100	45 x 100	30 x 100
75 x 150	45 x 150	30 x 150
75 x 200	45 x 200	30 x 200
100 x 150	60 x 150	40 x 150
100 x 200	60 x 200	40 x 200

HEXATECH	<b>Electrical Method Statement for Conduit, Trunking, Tray, Ladder and Cabling Installation</b>	Issue No.: 1	Document Effective Date: 01 Mar 2017	Page 3 of 14
		Rev. No.: 0		Document Ref: MS-E008

Insert the spring nut anywhere along the continuous slotted channel. The rounded nut ends permit easy insertion.

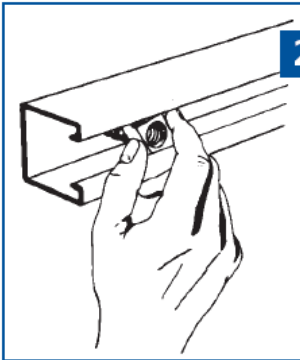
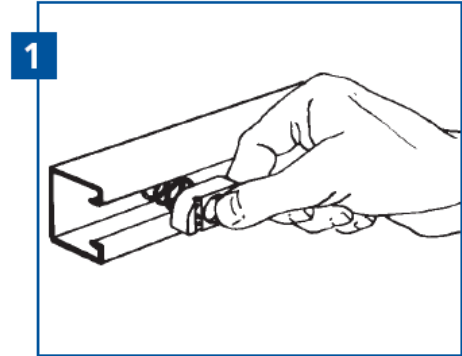

**2** A 90° clockwise turn aligns the grooves in the nut with the inturned edges of the channel.

Fittings can be placed anywhere along the channel opening, permitting complete freedom of adjustment. The need for drilling holes is eliminated.

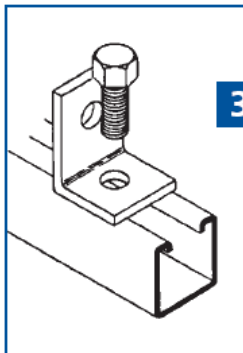

**3** Insert the bolt through the fitting and into the spring nut. (See illustration 5 for end view showing the nut in place)

- 100% Adjustable
- 100% Reusable
- No Welding
- No Drilling
- No Special Tools

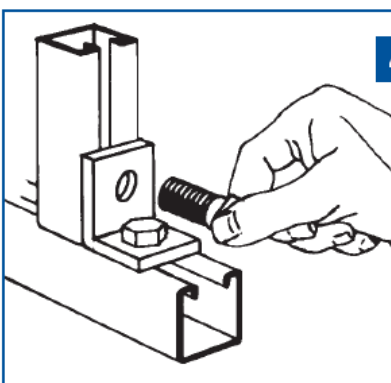

**4** Additional channel sections can now be bolted to the fitting already in place by following procedure described in steps 1–3.

Tightening with a wrench locks the serrated teeth of the nut into the inturned edges of the channel, to complete a strong, vise-like connection.

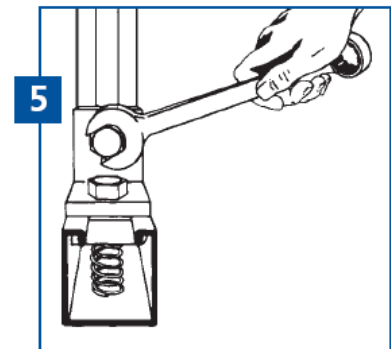

DIAGRAM A

HEXATECH	<b>Electrical Method Statement for Conduit, Trunking, Tray, Ladder and Cabling Installation</b>	Issue No.: 1	Document Effective Date: 01 Mar 2017	Page 4 of 14
		Rev. No.: 0		Document Ref: MS-E008

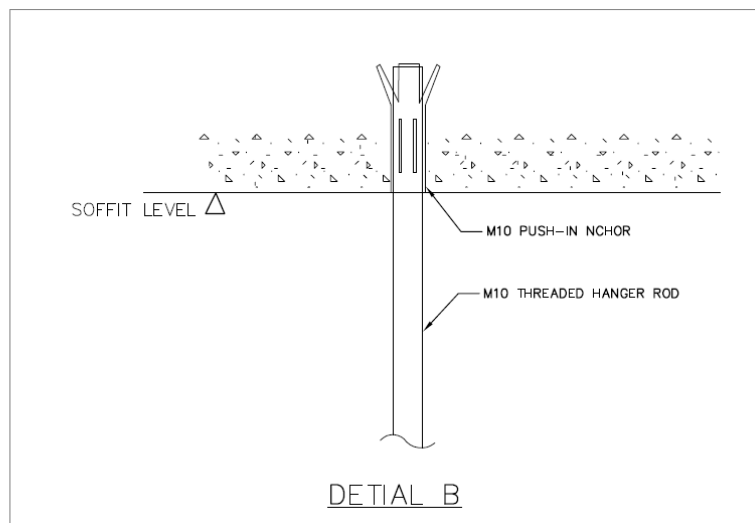
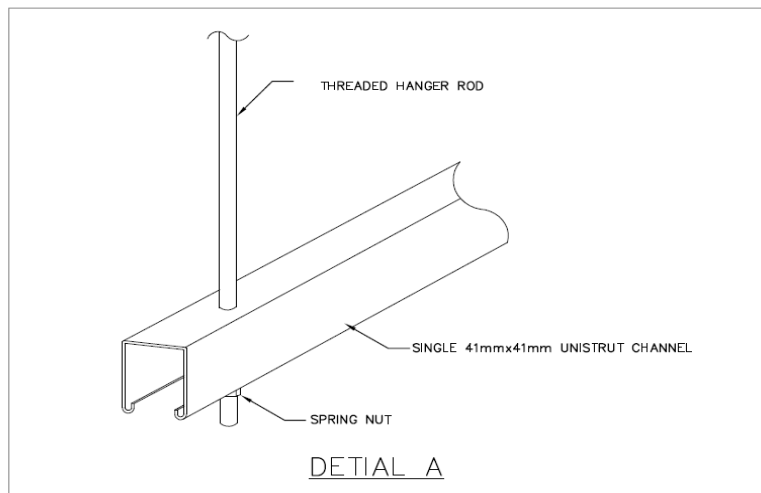
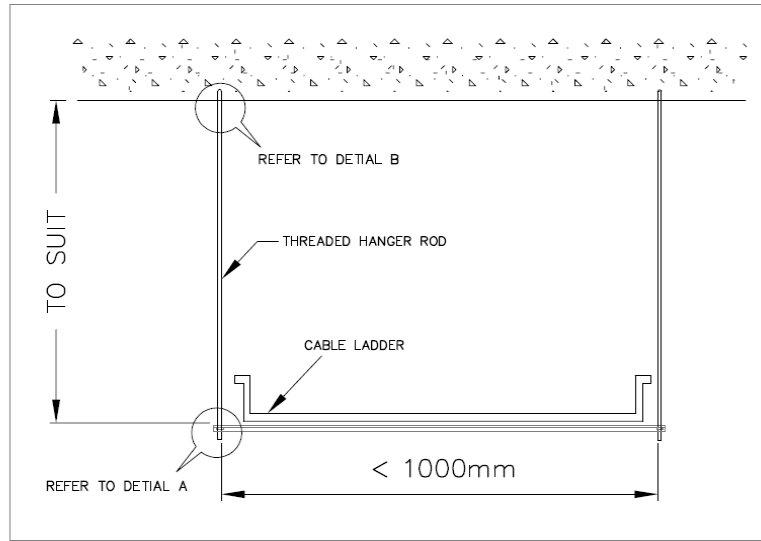
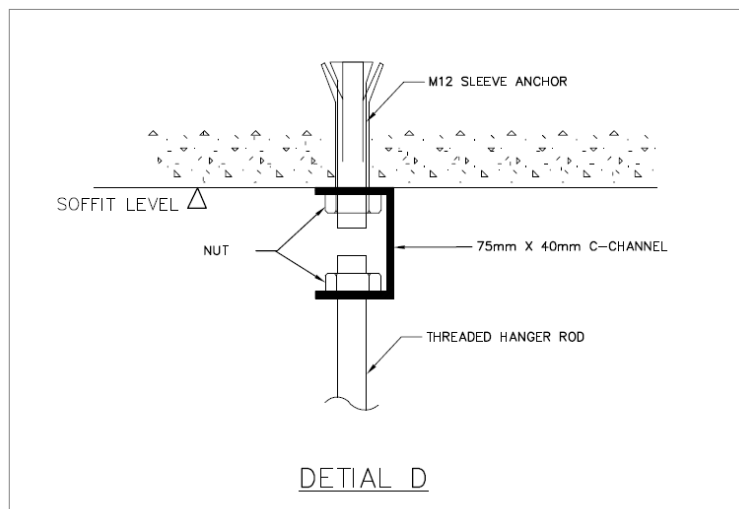
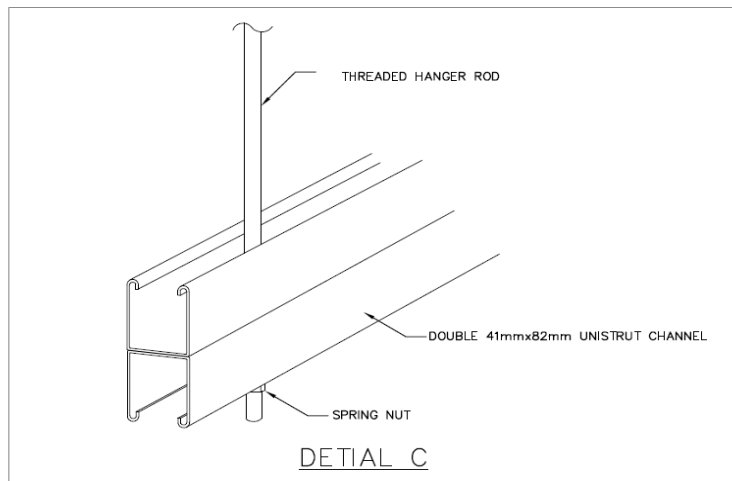
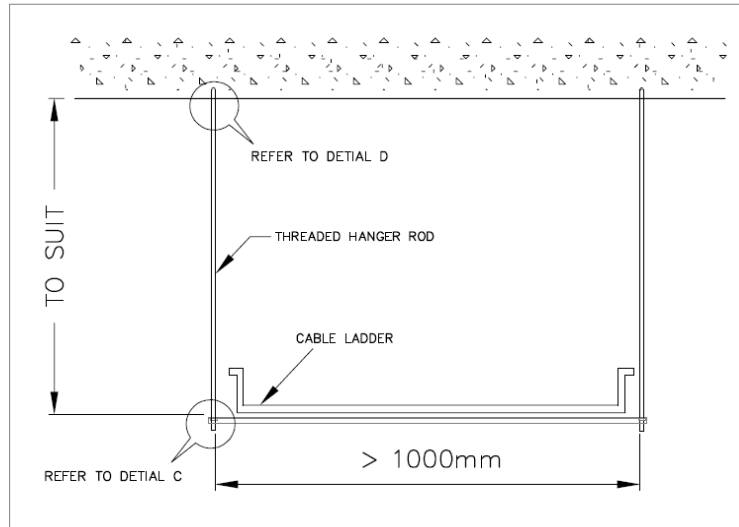

DIAGRAM B

HEXATECH	<b>Electrical Method Statement for Conduit, Trunking, Tray, Ladder and Cabling Installation</b>	Issue No.: 1	Document Effective Date: 01 Mar 2017	Page 5 of 14
		Rev. No.: 0		Document Ref: MS-E008



HEXATECH	<b>Electrical Method Statement for Conduit, Trunking, Tray, Ladder and Cabling Installation</b>	Issue No.: 1	Document Effective Date: 01 Mar 2017	Page 6 of 14
		Rev. No.: 0		Document Ref: MS-E008

Below is the typical cable raceway layout:

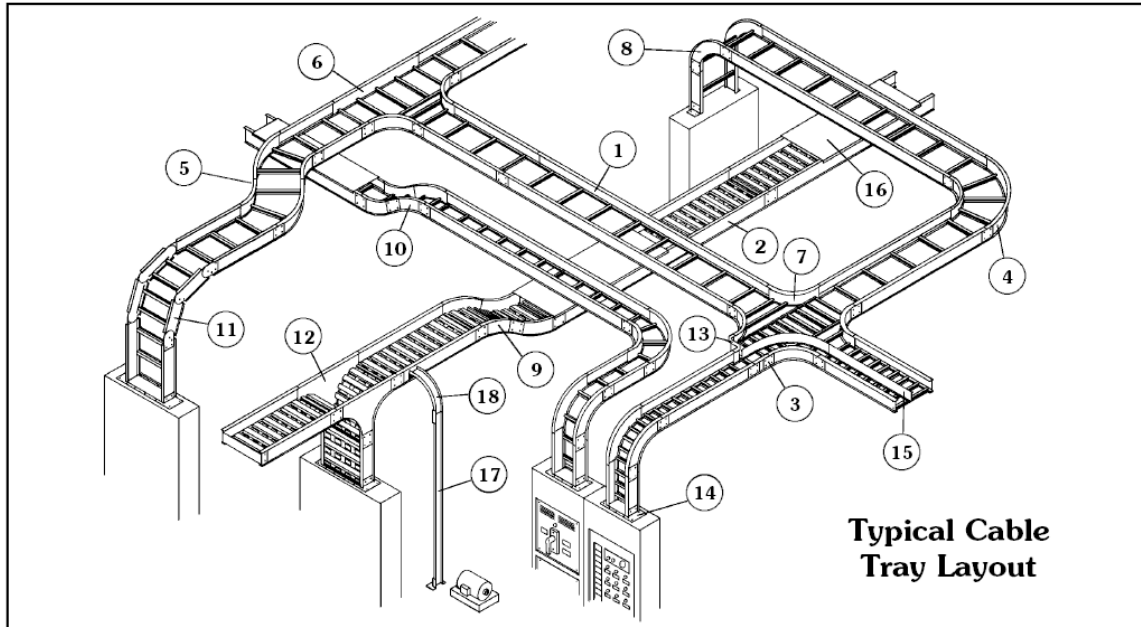

### 5.2.2 Conduit Installation

- The conduit shall be chosen as not to interfere with other accesses to the equipment and at least 2.3m above walking surface for operation and maintenance. The detailed routing and location shall be determined in the field to suit the location for equipment and to conform to the structural features to avoid interference with other systems.
- All conduits shall be neatly aligned, levelled and adequately supported at regular interval no more than 1.5m apart.
- Cable supports shall be fastened to steel with appropriate brackets or beam clamp/clip.
- Conduit pipe is used for the mechanical protection of wires. In this conduit wiring, wires are carried through steel or iron pipes, giving good protection to wires from mechanical injury or fire risks. Following are the types of conduit: -
  1. Screwed conduits. Screwed conduit solid drawn or with welded, seam pipe, is used for all mediums pressure (230V to 650 volts) and cases where a good degree of mechanical perfection and absolute protection from moisture is required.
  2. Flexible conduit. Flexible conduit is pipe made up of flexible steel tube composed of concave metal strips, wound spirally up each other in such a way as to interlock their concave surface.
- Surfaced Conduit Wiring is fixed on the wall by means of saddles, screwed to rawl plug with wooden Gutties embedded on the wall. The saddles are also available to various types such as single and multiple saddles. Multiple saddles are used for holding two or more lengths of conduit at one fixing.

HEXATECH	<b>Electrical Method Statement for Conduit, Trunking, Tray, Ladder and Cabling Installation</b>	Issue No.: 1	Document Effective Date: 01 Mar 2017	Page 7 of 14
		Rev. No.: 0		Document Ref: MS-E008

### Maximum Number of Cables in Conduit

Size	16mm (5/8")	19mm (3/4")	25mm (1")	32mm (1 ¼")	38mm (1 1/2")	50mm (2")
1.5mm sq	4	6	13	21	32	-
2.5mm sq	3	5	9	16	23	42
4.0mm sq	2	3	7	11	17	30
6.0mm sq	-	2	5	9	13	24
10mm sq	-	-	4	7	9	17
16mm sq	-	-	3	5	7	13

- Precaution for conduit wiring:
  1. Edges of conduit should be filed before the laying so that there are no sharp edges.
  2. The conduits must be cleaned and dried thoroughly before the laying.
  3. Earth Continuity should be maintained at all joints.
  4. Over-crowding of wires should be avoided.
  5. The bending of pipes should be done by pipe bending machine.
- Conduit Pipe Fitting:
 

The following operations are to be performed during the installation of conduit pipe: -

  1. Pipe Cutting. The conduit pipe should be held firmly in the pipe vice and cut it with a hack saw or cutter. The sharp edges of the conduit should be filed so that insulation of the wires may not be damaged.
  2. Pipe Threading. After cutting and filing, the required length of conduit pipe can be acquired with pipe dies together with the thread oil. Press the dies firmly against the pipe until it holds the pipe. The chips must be blown away and apply more oil during the process for two or three times before the cut is completed. The die is then removed.
  3. Pipe Bending. The bending of pipes is done by using conduit bender.
  4. Pipe Assembling by conduit fitting means assembly of pipe with various pipe accessories.

### 5.2.3 Cabling Installation

- The maximum allowable occupancy area in a cable tray shall not exceed 70% of the total cable tray/trunking area after cables are laid.
- Cables with different voltage rating shall be segregated in the tray/trunking at all times.
- The single conductor cables are preferably installed in phase-bundles of 3 (trefoil) or 4 (quadroplexed) with their respective ground and neutral conductor. Bundles of cables with same phase are strictly prohibited.
- Cables installed on tray/ladder shall be fastened not more than 1.5m apart.
- All cables terminated at switchboard end must be neatly arranged and labeled.
- Pre-Installation
 

Prior to installation, the followings need to be confirmed: -

  1. The cable selected is suitable for application and as per drawings.
  2. The cable has not been damaged during transit and storage.

HEXATECH	<b>Electrical Method Statement for Conduit, Trunking, Tray, Ladder and Cabling Installation</b>	Issue No.: 1	Document Effective Date: 01 Mar 2017	Page 8 of 14
		Rev. No.: 0		Document Ref: MS-E008

3. Cable Inspection. Inspect every cable reel for defects before accepting the shipment. Be particular alert for cable damage if:
  - A reel is laying flat on its side
  - Several reels are stacked
  - Other freight is stacked on a reel
  - Nails have been driven into reel flanges to secure shipping blocks
  - A reel flange is damaged
  - A cable end seal is removed or damaged
  - A reel has been dropped (hidden damage likely)
4. Cable Handling. Remove all nails and staples from the reel flanges before removing a reel, and avoid all objects that could crush, gouge or impact the cable when moving. Use swivels for unreeling to prevent twisting and avoid overruns.
5. Cable Storage. Cables should be stored on hard surfaces to prevent reel flanges from sinking. Prevent impact damage by:
  1. Aligning reels flange to flange
  2. Using guards across flanges when different reel sizes are stored together
  3. Maintaining adequate aisles and barricades to prevent equipment from hitting the cables
  4. Seal the ends of all cable stored outdoors and reseal both ends when a length is cut from the reel.
6. The following minimum spacing between instrument cable and power cables shall apply where cable runs are parallel for distances exceeding one meter:

Power Cable Rating	Minimum Instrument Cable Separation Distance
Cable $\geq$ 220V 1phase or $\geq$ 380V 3 Phase	300mm
Cable Ampere $\geq$ 200A	300mm
Cable $\geq$ 3300V	600mm

7. Where high and low voltage power cables are run parallel for distances exceeding one meter, there shall be a minimum of 100mm separation distance between the cables.

#### 5.2.4 Cable Termination

1. Proper glands shall be provided for all cables terminating on switchboards, equipment etc. unless otherwise specified.
2. Single core cables in steel enclosure will cause electromagnetic currents in the steel and possible overheating. This can be avoided by ensuring that a non-ferromagnetic material is used around the cables (e.g. brass plate or bakelite) or slots are cut in the steel between the phase conductors.

HEXATECH	<b>Electrical Method Statement for Conduit, Trunking, Tray, Ladder and Cabling Installation</b>	Issue No.: 1	Document Effective Date: 01 Mar 2017	Page 9 of 14
		Rev. No.: 0		Document Ref: MS-E008

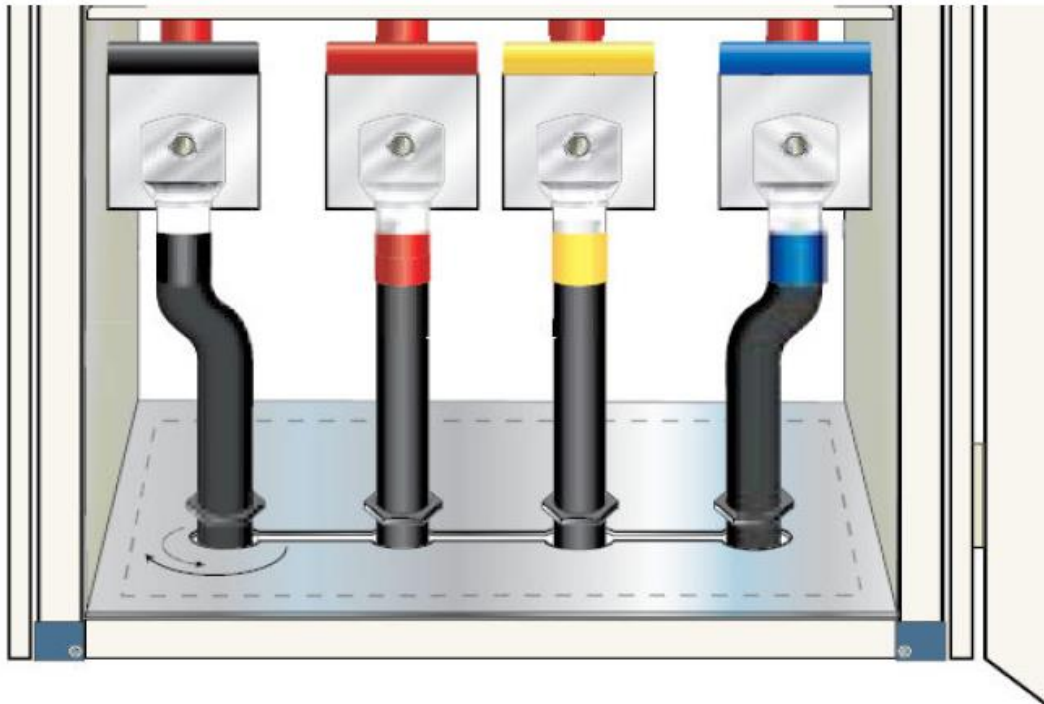

### 5.2.5 Hacking of brick-wall to create opening:

- Firstly, determine the location and mark out the size of opening required with lines drawn according to the measurement.
- Cover one side of the wall with canvas sheet as safety measure and protection to minimize straying of debris from the hacking activity
- Drill holes along the lines drawn at 100mm to 150mm intervals with hammer-drill as well as within the area of section of wall to be removed.
- Hack the wall within the marked out lines with sledge hammer and level and smoothen the hacked surfaces with hammer and chisel to the desired size of the openings.
- Clear all debris created by the activity from site.
- The opening is ready for use by installer of cable-tray.

## 6.0 INSPECTION AND TESTING

### 6.1 Inspections:

All testing and inspections will be documented with request for inspection form, test reports and inspection documents as indicated in the approved inspection and test plan.

The inspection at site shall be conducted in two stages.

#### a) Receiving Inspection

The receiving inspection is carried out to assure conformance to specification. Rejection or acceptance of delivered equipment shall be by the discretion of the Project Engineer with verification by client's personnel. Result will be captured in request for inspection form and Material Receiving Inspection Report.

HEXATECH	<b>Electrical Method Statement for Conduit, Trunking, Tray, Ladder and Cabling Installation</b>	Issue No.: 1	Document Effective Date: 01 Mar 2017	Page <b>10</b> of <b>14</b>
		Rev. No.: 0		Document Ref: MS-E008

## b) In-process and Final Inspection

The in-process inspection shall be carried out to assure conformance of the installation works as indicated in project specifications. Rejection or acceptance of installation will be captured in request for inspection form, verified by client's personnel.

### 6.2 Testing:

#### Continuity Test

1. Tests should be carried out by using the appropriate test equipment.
2. Two circuits will be tested to verify that the cable is not damaged/cut during installation. Permanent labels will be applied after circuit verification.
3. Test result to be captured in test report.

#### Phase Rotation Test

1. Tests should be carried out by using the appropriate test equipment.
2. Phase rotation test is applicable for 3-phase only.
3. Test result to be captured in test report. Anti-clockwise or clockwise.

Test voltages and the minimum acceptable values of insulation resistance

#### Insulation-resistance test

1. Tests should be carried out by using the appropriate DC voltage tester.
2. Make sure the main switch is off and all fuses are in place, switches and circuit breakers closed up, lamp removed and other current equipment is disconnected.
3. Test should be carried out as below: (Fig.4)
  - a. Insulation resistance between live conductors
  - b. Insulation resistance to earth

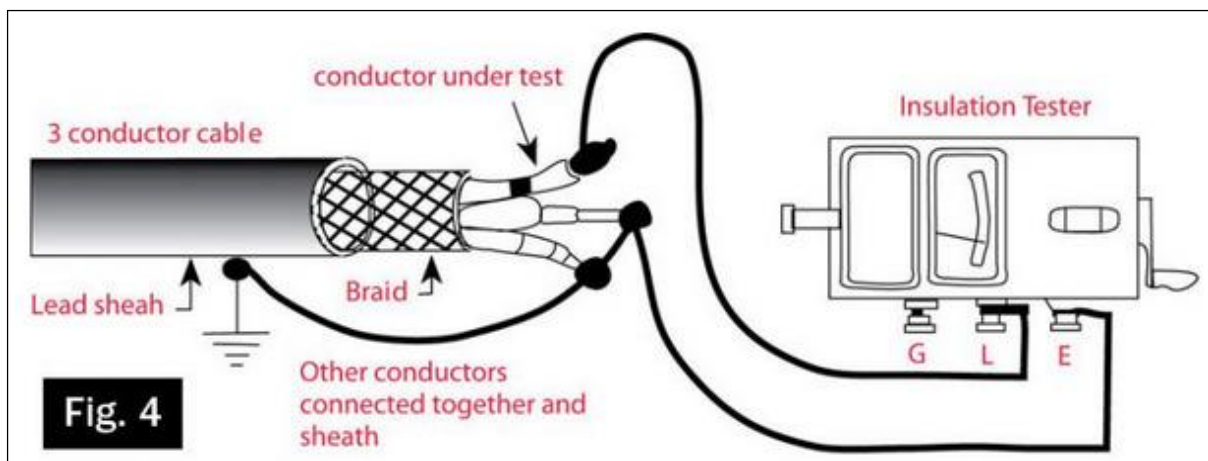

This table indicates the test voltages and the minimum acceptable values of insulation resistance.

HEXATECH	<b>Electrical Method Statement for Conduit, Trunking, Tray, Ladder and Cabling Installation</b>	Issue No.: 1	Document Effective Date: 01 Mar 2017	Page <b>11</b> of <b>14</b>
		Rev. No.: 0		Document Ref: MS-E008

<b>Cable Voltage (Working Range)</b>	<b>Test Voltage (Between conductor and to earth)</b>	<b>Minimum Insulation Resistance (Mega Ohms)</b>
Control Wiring	500V	10
450/750V	500V	10
600/1000V	1000V	100
1900/3300V	1000V	200
3800/6600V	1000V	200
6350/11000V	5000V	200
8700/15000V	5000V	200
12700/22000V	5000V	200
19000/33000V	5000V	200
38000/66000V	5000V	200

HEXATECH	<b>Electrical Method Statement for Conduit, Trunking, Tray, Ladder and Cabling Installation</b>	Issue No.: 1	Document Effective Date: 01 Mar 2017	Page <b>12</b> of <b>14</b>
		Rev. No.: 0		Document Ref: MS-E008

## A19(a) Measurement of earth electrode resistance

---

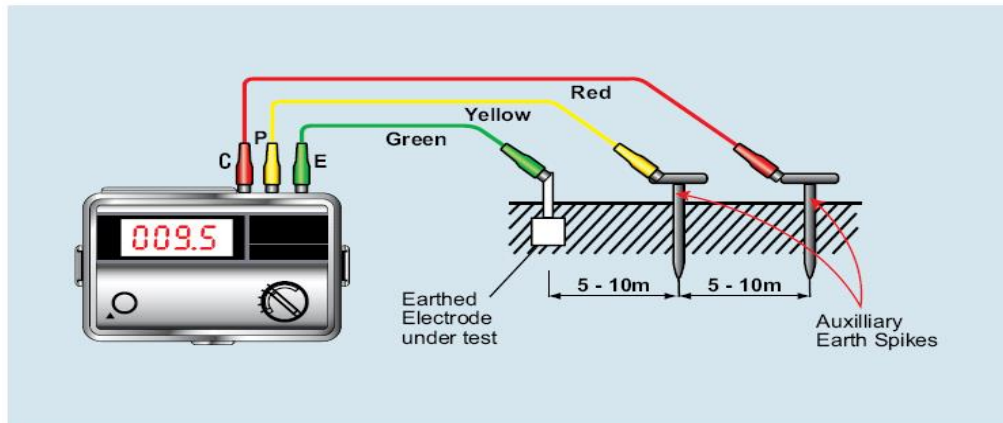

- (i) a proprietary earth electrode test device should be used
- (ii) auxiliary earth spikes should be applied at least 5 m apart and 5 m distant from the electrode under test
- (iii) an earth resistance value of less than 10 ohms is required for a Customer Earthed System [ see Regulation 6.2 ].
- (iv) an additional number of electrodes may be required (or deeper electrodes) to achieve the required earth resistance value
- (v) due consideration should be given to future changes in soil condition (e.g. drying out)
- (vi) sufficient time should be allowed if special chemicals or salts are added to the ground to improve the earth resistance values



Earth Pit



Earth Test Spike

HEXATECH	<b>Electrical Method Statement for Conduit, Trunking, Tray, Ladder and Cabling Installation</b>	Issue No.: 1	Document Effective Date: 01 Mar 2017	Page <b>13</b> of <b>14</b>
		Rev. No.: 0		Document Ref: MS-E008

## 7.0 HEALTH, SAFETY, SECURITY AND ENVIRONMENT

- All installation works will be carried-out in accordance with Project Safety & Environmental Plan, client's Safety Procedures and statutory regulations.
- All necessary personal protective equipment will be provided and worn.
- All the tools and equipments used at site must be compliance to safety requirement.
- The site of all work activities will be kept in clean and tidy manner.
- Safety personnel will closely supervise and checked the safety of the construction area. Safety measure will be intensified when the risk is higher during period of work.

MCC TECHNIQUE SDN. BHD.	METHOD STATEMENTS	Issue No.: 1	Document Effective Date: 01 Aug 2017	Page 14 of 14
	Electrical Method Statement for Conduit, Trunking, Tray, Ladder and Cabling Installation	Revision No.: 0		Document Ref: MS-E008

## 8.0 LIST OF ATTACHMENT

Attachment	Description	Remarks
1	List Of Material, Tools and Safety Facilities	

### ATTACHMENT 1: LIST OF MATERIAL

List of Material	
<b>A</b>	<b>Equipment and tools</b>
1	Electrical Drill
2	Electrical Grinder
3	Screw drives
4	Hand Drill
5	Hammer Drill
6	Sledge Hammer
7	Masonry Chisel
8	Hammer Canvas Sheet
9	Fiber Cutter
10	Pliers
11	Cutter
12	Jig Saw
13	Bend Saw
14	Vice
15	Die
16	Bender
17	Water Level
18	Measurement Tape
19	Spanners
20	Hand Saw
21	Blade
22	Punch
23	Hammer
24	Cable Stand Jack
25	Ladder
26	Scaffolding
27	Scissor Lift
<b>B</b>	<b>Safety tools</b>
1	Safety helmet
2	Safety shoe
3	Hand Glove
4	Goggles
5	Safety Harness
6	Basic First aid Kit

End